

# WALL-MAN® XL 1300

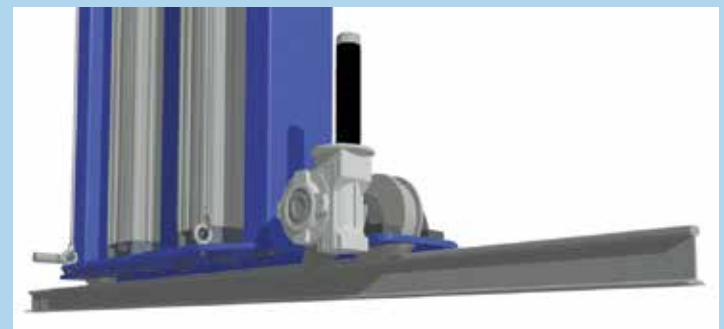

- Made to order
- Non slip floor in cage
- Three dimensional movement
- ATEX approved



<b>Construction</b>	Welded Steel	
<b>Finish</b>	RAL 5015	
<b>Payload</b>	250 kg (2 persons plus equipment)	
<b>Controls</b>	<b>In cage:</b> Up/Down; Left/Right; In/Out	<b>At ground Level:</b> Up/Down
<b>Air Supply</b>	6 - 8 bar. 350 litres per minute supplied via hoses on self-retracting hose reels. A compressed air outlet for air tools is provided in the cage.	

<b>Key Dimensions</b>	<ul style="list-style-type: none"> <li>• Height of raised platform ..... 6000 mm <i>(may be reduced to 4000 mm)</i></li> <li>• Height to top of upper rail ..... 6800 mm <i>(may be reduced to 4750 mm)</i></li> <li>• Distance from wall to front of cage ... 1390 mm <i>(fully retracted)</i> 2690 mm <i>(fully extended)</i></li> <li>• Cage size (W x D) ..... 2005 x 820 mm.</li> </ul>
-----------------------	--------------------------------------------------------------------------------------------------------------------------------------------------------------------------------------------------------------------------------------------------------------------------------------------------------------------------------------------------------------------------------------------------

**Installation** The platform runs on a rail fixed on the floor. The upper rail is mainly used as a guide rail.

**Imposed Loads** *The following data relates to the standard model only.  
For platforms with height or off-set variations; please ask for specific information.*

• Upper Rail, Vertical Load: 0 kg	• Lower Rail, Vertical Load: 1040 kg
• Upper Rail, Horizontal Load: 163 kg	• Lower Rail, Horizontal Load: 163 kg

